

Socionext Develops World's First Demodulator IC Compatible with Both ISDB-S3 Satellite Broadcasting and ITU-T J.183 Based Channel Bonding Technology

--- Accelerates the popularization of 4K and 8K broadcasting through satellites and cables ---

Yokohama, September 29, 2016 --- Socionext Inc., a leading provider of advanced SoC solutions for digital TV, has developed the world's first demodulator IC that is compatible both with the Advanced Wide-Band Digital Satellite Broadcasting (ISDB-S3) and ITU-T Recommendation J.183 based channel bonding technology.

The new SC1501A can receive both the direct signals from the satellites and the retransmission of satellite signals through cable systems (IF pass-through, transmodulation) for 4K and 8K broadcasting. Socionext has also developed prototype receiver systems equipped with the SC1501A, one of which will be used in the experimental retransmission of Advanced Wide-Band Digital Satellite Broadcasting through the cable TV system, jointly conducted by Nippon Hoso Kyokai (NHK), KDDI Corporation (KDDI), Jupiter Telecommunications Co., Ltd. (J:COM), and Japan Digital Serve Corporation (JDS).

Socionext will showcase the SC1501A and the prototype receiver systems at CEATEC Japan, held at Makuhari Messe in Chiba, Japan starting Tuesday, October 4th.

Socionext is a leading provider of digital TV solutions based on its long-time expertise on video signal processing technologies. The company recently developed the world's first single-chip 8K HEVC video decoder.

In Japan, test broadcastings of 4K and 8K have started, and the full services are scheduled in 2018. Testing and prototyping is underway across the industry, aiming for the popularization of the broadcasting formats by 2020.

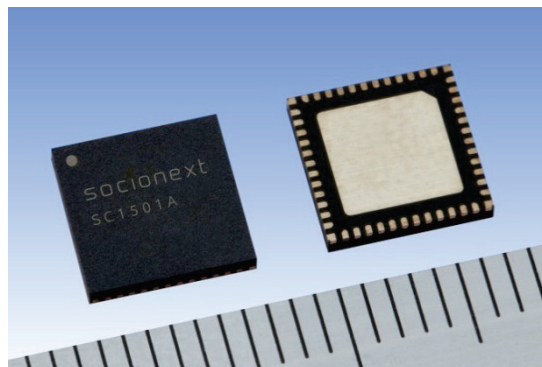

Photo 1: SC1501A

[View Larger Image](#)

A digital receiver system that can handle various kinds of transmission schemes is essential to promote the wider use of 4K and 8K broadcasting. Socionext has developed SC1501A, a demodulator IC that is compatible both with the Advanced Wide-Band Satellite Broadcasting

For Press Inquiry

Public Relations

Socionext Inc.

Tel: +81-45-568-1006

Inquiry Form <http://socionext.com/en/contact/>

(ISDB-S3), and channel bonding technology based on ITU-T J.183. The chip is capable of receiving various form of signals including direct signals from the satellites, as well as retransmission through cables such as IF pass through and transmodulation. Equipment makers can utilize the SC1501A in combination with Socionext's codec and digital TV SoC products to easily develop receiver systems such as TVs, recorders, and set-top-boxes.

The experimental retransmission of Advanced Wide-Band Digital Satellite Broadcasting through the cable TV system will be jointly conducted by Nippon Hoso Kyokai (NHK), KDDI Corporation (KDDI), Jupiter Telecommunications Co., Ltd. (J:COM), and Japan Digital Serve Corporation (JDS). Socionext has developed a prototype of receiver equipped with the SC1501A, to be used in the cable retransmission experiment.

In addition to the prototype receiver used for the experiment by the four companies, Socionext has developed another prototype designed only for direct satellite signal. These two prototype receivers, for "ISDB-S3 (satellite) and ITU-T J.183-based channel bonding" and for "ISDB-S3-only", are to be used as the reference models for equipment makers, to help expand Socionext's visual systems businesses.

Socionext will showcase the SC1501A and the prototype receiver systems at CEATEC Japan, held at Makuhari Messe in Chiba, Japan from Tuesday October 4th.

For more information about CEATEC Japan, visit: <http://www.ceatec.com/ja>

About Socionext Inc.

Socionext is a new, innovative enterprise that designs, develops and delivers System-on-Chip products to customers worldwide. The company is focused on imaging, networking, computing and other dynamic technologies that drive today's leading-edge applications. Socionext combines world-class expertise, experience, and an extensive IP portfolio to provide exceptional solutions and ensure a better quality of experience for customers. Founded in 2015, Socionext Inc. is headquartered in Yokohama, and has offices in Japan, Asia, United States and Europe to lead its product development and sales activities. For more information, visit socionext.com.

All company or product names mentioned herein are trademarks or registered trademarks of their respective owners. Information provided in this press release is accurate at time of publication and is subject to change without advance notice.

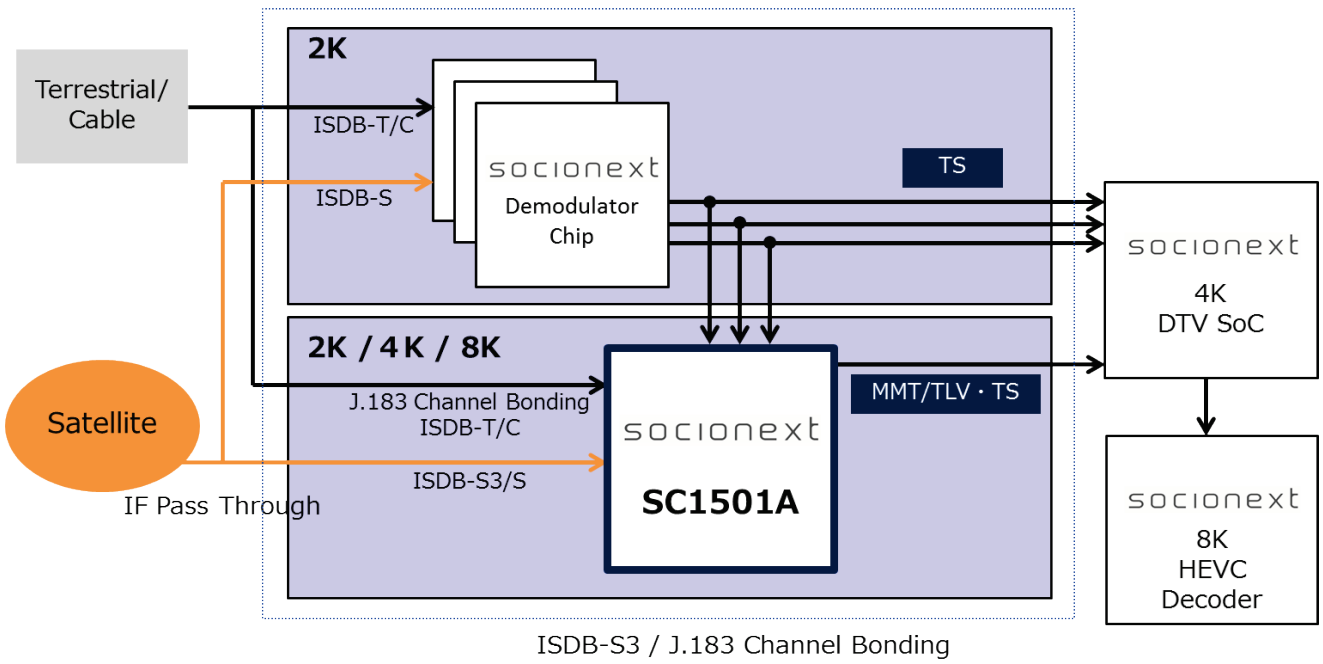

Figure 1: SC1501A and the Receiver System

[View Larger Image](#)

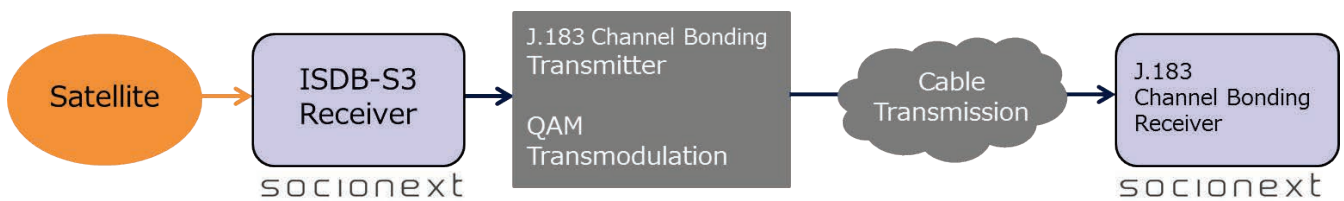

Figure 2: Outline of the Experimental Retransmission

[View Larger Image](#)

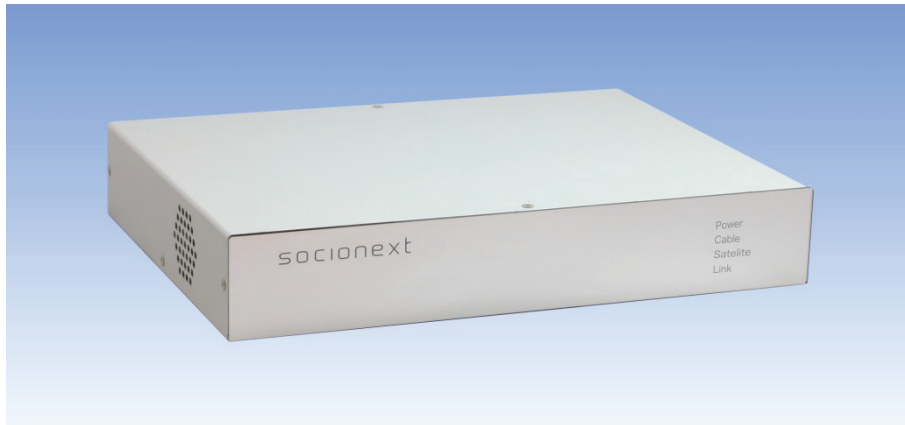

Photo 2: Prototype Receiver
(for ISDB-S3 Satellite Broadcasting & ITU-T J.183 Channel Bonding)
[View Larger Image](#)



Photo 3: Prototype Receiver
(for ISDB-S3 Only)
[View Larger Image](#)