

Socionext Develops New Large Scale, High Efficiency Distributed Processing Server, Fully Utilizing Multi-Core Processors

Drastically Improves the Power Efficiency through Direct Data Transaction Technology

Sunnyvale Calif. and Yokohama, December 28, 2016 --- Socionext Inc, an emerging leader in SoC-based solutions for today's computing needs, has developed a new high speed, low power consumption and scalable server, based on the company's multi-core processor "SC2A11" (link to [product page](#)) and the new high speed CPU-to-CPU communication technology. The new server achieved power consumption as low as one-third of conventional products when running a distributed processing application. Built in a single chassis, it delivers the same performance as a conventional system consisting of a high-speed switch device and multiple servers. The server offers optimum solution for online services and cloud applications.

Servers for online services and cloud applications need to process large amounts of data at the same time, even though individual tasks are relatively small-loaded. In these applications, virtualization of CPU and OS can deal with the varying processing demands flexibly; however, power consumption required by overhead from virtualization has remained an issue. It is proven effective to distribute the processes directly to large numbers of physical CPUs in order to eliminate overhead. Socionext calls this approach "Direct Distributed Computing". To realize this method however, it is essential to use a technology that supports the high speed communication between CPUs.

Socionext has developed a CPU-to-CPU communication technology "Socionext DDT (Direct Data Transaction) and the switch SoC SC2A20 in which the technology is implemented. While the conventional server systems connect CPUs through a dedicated high speed bus which consumes high power or conventional Ethernet, The SC2A20 provides input/output through PCI – Express®, enabling high speed communication between CPUs at low cost (patent pending). In order to demonstrate the efficiency of Direct Data Transaction technology and Direct Distributed Computing, Socionext has developed a server with the SC2A20, connecting the SC2A11 multi-core processors in cascade. It has been confirmed that the prototype of the server

For Press Inquiry

Public Relations

Socionext Inc.

Tel: +81-45-568-1006

Inquiry Form <http://socionext.com/en/contact/>

achieved power consumption as low as one-third of conventional server systems based on virtualization, at the same CPU performance.

Socionext also performed TeraSort benchmarking on using Apache™ Hadoop®, a large-scale distributed file system. It took 605 seconds for processing of 25GB of data, when using 7 CPUs. Previously, a larger system with a switch device and multiple servers was necessary to deliver the similar performance. Socionext has achieved the result with a single-chassis server. Now the company is using the prototype to verify OpenStack®, an emerging cloud application, as well as to validate the server's scalability.

The server's benchmarking on Apache Hadoop will be demonstrated at CES 2017 in Las Vegas, from January 5 to 8, 2017.

Socionext aims at spreading Direct Distributed Computing to revolutionize servers and continue developing and delivering related products and services.

About Socionext Inc.

Socionext is a new, innovative enterprise that designs, develops and delivers System-on-Chip products to customers worldwide. The company is focused on imaging, networking, computing and other dynamic technologies that drive today's leading-edge applications. Socionext combines world-class expertise, experience, and an extensive IP portfolio to provide exceptional solutions and ensure a better quality of experience for customers. Founded in 2015, Socionext Inc. is headquartered in Yokohama, and has offices in Japan, Asia, United States and Europe to lead its product development and sales activities. For more information, visit socionext.com.

All company or product names mentioned herein are trademarks or registered trademarks of their respective owners. Information provided in this press release is accurate at time of publication and is subject to change without advance notice.

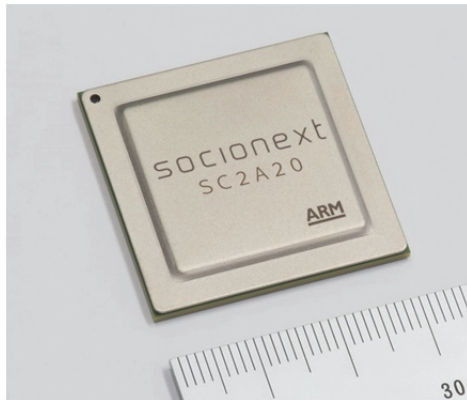

Photo 1: SC2A20

[View Larger Image](#)

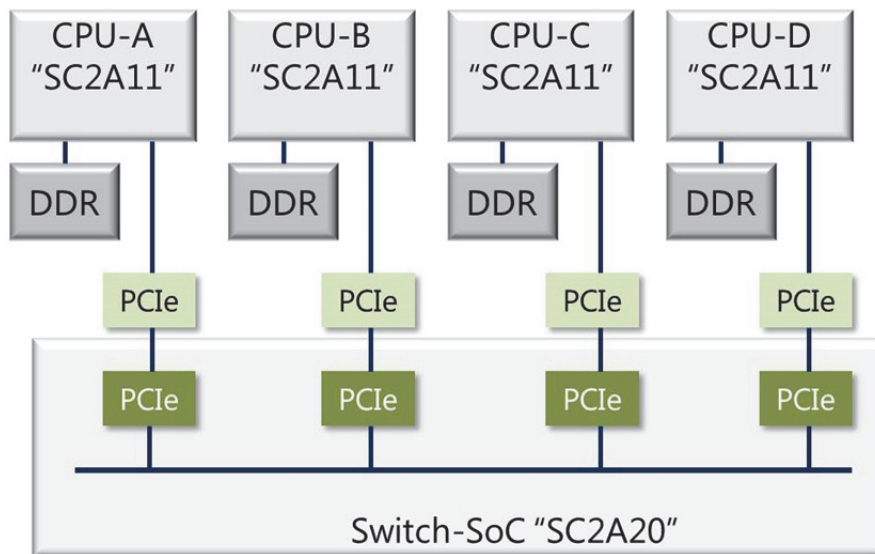

Figure 1: CPU Connection by SC2A20

[View Larger Image](#)

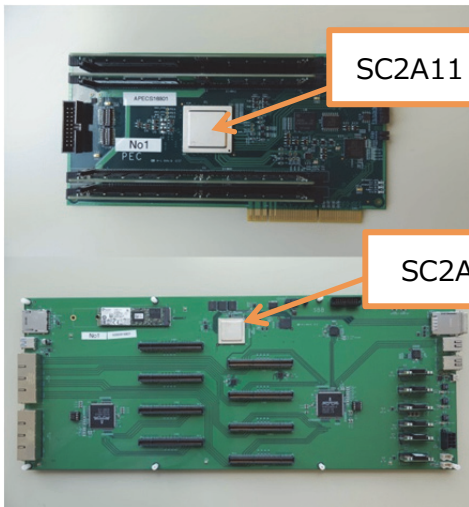

Photo 2a.

Top: Processor Element Card (PEC)

Bottom: System Bridge Board (SBB)

[View Larger Image](#)

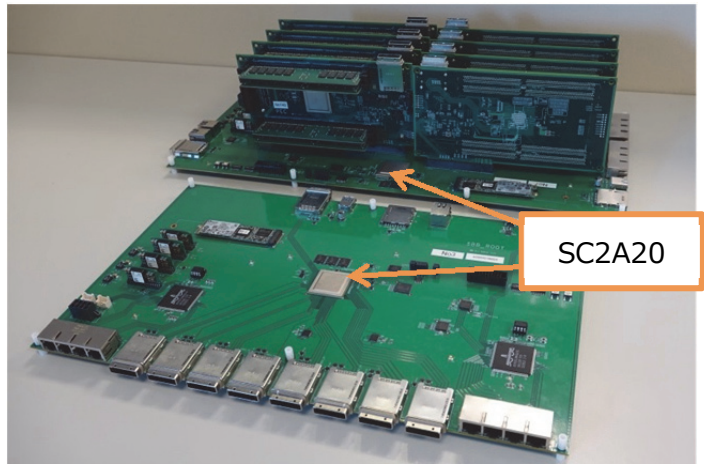

Photo 2b.

Back: SBB with 8 PECs inserted

Front: Top Of Rack Board (TOR)

[View Larger Image](#)

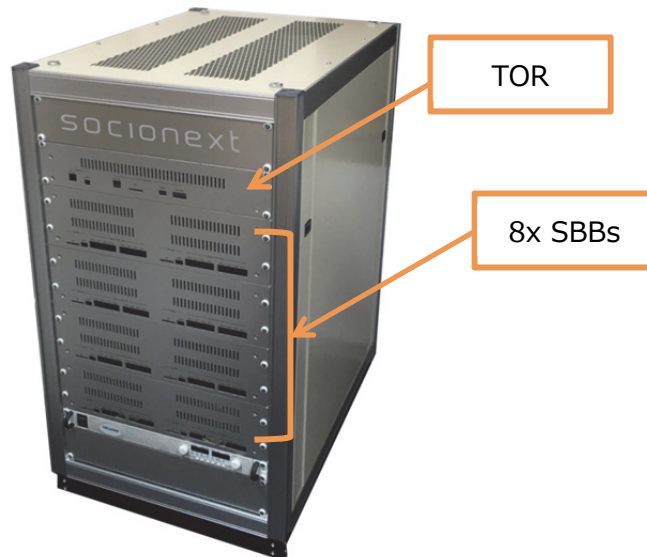

Photo 2c. Prototype Server for Direct Distributed Computing

1 TOR + 8 x SBB (8 PECs on each SBB) = Total 64 CPUs

[View Larger Image](#)